



Operating and Maintenance Instructions

ROTARY CLAW VACUUM PUMPS AND COMPRESSORS

MODELS VCX AND PCX



INSTALLATION & OPERATING MANUAL

ROTARY CLAW VACUUM PUMPS AND COMPRESSORS

Table of Contents

Section:	Page Number:
1.0 Description	3
2.0 Application Range	3
3.0 Application Limits	4
4.0 Cooling and Noise	4
5.0 Motor	4
6.0 Installation and Start-Up	5
7.0 Routine Maintenance	7
8.0 Troubleshooting Chart	9
9.0 Safety	13
10.0 Storage	13
11.0 Disposal	13
12.0 Drawings	14

1.0 Description

The Airtech Vacuum, Inc. rotary claw vacuum pumps and compressors are dry, contactless machines. Two claws rotate in opposite directions in a housing. The rotation of the complex shaped claws is regulated by a gear set. The gears and inside bearings are lubricated by gear oil using a splash lubrication principle. For models 7.5 HP and below, there is only one set of bearings on the drive side. For larger models, a grease lubricated bearing is added at the non-drive side of the claw to prevent excessive deflection as the claws become large.

Rotary claw systems are suitable for pumping a variety of gases at vacuum levels to 28 inches Hg and to pressures of up to 30 psig. Operation on humid air and with explosive gases requires special construction and accessorization customized to the application. When not operating on air, please contact your Airtech sales representative for assistance.

2.0 Applicable Range

The Airtech VCX claw pumps are available in a wide range of sizes from 3.0 Horsepower to 15 Horsepower. PCX pumps are identical in internal construction to VCX vacuum pumps, but are outfitted with different inlet and outlet accessories to allow for operation as a compressor. When operated as a compressor, it is important to size the motor to meet the necessary power requirements for the anticipated discharge pressure of the application.

Table 2-1 Vacuum and Pressure Limits of Airtech VCX and PCX Claw Pumps

Model	Maximum Vacuum in VCX Configuration	Maximum Discharge Pressure in PCX Configuration
100	25.5 inches Hg vacuum	32 psig
150	27.0 inches Hg vacuum	29 psig
250	24.0 inches Hg vacuum	32 psig
300	24.0 inches Hg vacuum	32 psig
500	22.5 inches Hg vacuum	32 psig

Caution – Operation below the maximum vacuum level or above the maximum discharge pressure may result in failure of and severe damage to the machine.

3.0 Application Limits

The base machine design in standard configuration is for use on dry air only. Handling of humid air or gases containing aggressive chemicals (acids, bases, hydrocarbons, etc...) is possible only with specially configured units. Consult your Airtech sales professional for assistance.

Caution: Do not operate the VCX and PCX rotary claw vacuum pumps and compressors in ambient temperatures exceeding 104 F (40 C).

Caution: Do not operate the VCX rotary claw vacuum pump with excessive back pressure on the unit. The maximum allowable back pressure on the VCX unit is 2 psig. Pressures in excess of 2 psig on the discharge of the vacuum pump may result in excessive current draw. Contact your Airtech sales professional for assistance in cases where downstream back pressure is unavoidable.

Caution: Noise generation in excess of 85 dBA is possible with the VCX and PCX line of rotary claw pumps and compressors. Hearing protection should be worn when working within close proximity to the units for extended periods of time. If noise below 85 dBA is desired, an external sound enclosure can be added to the system, provided adequate ventilation is provided.

4.0 Cooling and Noise

The VCX and PCX units are enclosed in a sheet metal box containing sound deadening materials. The sheet metal box is configured to maximize the efficiency of the cooling air supplied by the coupling fan. Operation of the unit without the sheet metal box will result in excessive temperatures, loud operation and possibly shorten the life of the unit.

5.0 Motor

All VCX and PCX rotary claw vacuum pumps are equipped with a two-pole (3600 rpm) TEFC motor. Alternate motor configurations are possible, including adaptation to IEC or NEMA explosion proof configurations. To mount some explosion proof motors modifications to the mounting rails may be necessary. Contact your Airtech sales professional for advise if you require an explosion proof motor for your application.

6.0 Installation and Start-up

6.1.1.1 Place the VCX or PCX rotary claw vacuum pump or compressor on a level surface. The splash lubrication system for the timing gears requires that the unit be installed in the standard configuration only.

6.1.1.2 Ensure that adequate clearance is left around the compressor or vacuum pump. A minimum of 6 inches should be left around all surfaces to allow for adequate cooling air flow.

6.1.2.1 For the VCX vacuum pump, connect the inlet piping to the process.

6.1.2.2 Connect the motor to a magnetic motor starter using appropriate wiring sized for the maximum current draw shown on the motor nameplate. The motor starter should be sized to handle the full load current draw of the motor times the service factor of the motor as shown on the motor data plate.

Warning: Motors should only be installed by a qualified electrician, who has experience in wiring three-phase motors. Improper electrical installation can cause injury or death.

Caution: Maximum number of motor starts per hour should not exceed 10 per hour. Excessive starting of the motor can cause overheating and premature failure of the motor. A minimum run timer should be used with any panel that may control the pump with automatic starts and stops based on system pressures.

6.1.3 Add oil (ISO-VG 150 oil to DIN 51502: CLP HC 150 such as Shell Omala HD 150 Gear oil) to the gearbox until it is visible to the proper level (halfway up the sight glass).

Caution: Operation of the pump before adding the oil to the gearbox could result in severe damage to the VCX pump.

Caution: Use of oil that does not meet the recommended specification could result in premature damage to the VCX pump and void the warranty.

6.1.4 Check the direction of rotation by briefly energizing the motor and checking the direction of rotation of the motor fan against the arrow located on the motor fan housing. If the direction is opposite of the arrow, lock out the power and change two of the power leads into the motor. Check the direction once more to confirm that it is running in the proper direction.

6.1.5 During operation, ensure that the suction pressure does not exceed the maximum continuous operating vacuum as shown in Table 2-1. Adjust the vacuum regulator to

maintain the vacuum level desired by rotating the adjustment knob clockwise or counterclockwise, depending on adjustment desired.

6.2.1 For the PCX pump, connect the discharge pipe to the process.

6.2.1.1 Connect the motor to a magnetic motor starter using appropriate wiring sized for the maximum current draw shown on the motor nameplate. The motor starter should be sized to handle the full load current draw of the motor times the service factor of the motor as shown on the motor data plate.

Caution: Motors should only be installed by a qualified electrician, who has experience in wiring three-phase motors.

Caution: Maximum number of motor starts per hour should not exceed 10 per hour. Excessive starting of the motor can cause overheating and premature failure of the motor. A minimum run timer should be used with any panel that may control the pump with automatic starts and stops based on system pressures.

6.2.2 Add oil (ISO-VG 150 oil to DIN 51502: CLP HC 150 such as Shell Omala HD 150 Gear oil) to the gearbox until it is visible to the proper level (halfway up the sight glass).

Caution: Operation of the pump before adding the oil to the gearbox could result in severe damage to the PCX pump.

Caution: Use of oil that does not meet the recommended specification could result in premature damage to the VCX pump and void the warranty.

6.2.3 Check the direction of rotation by briefly energizing the motor and checking the direction of rotation of the motor fan against the arrow located on the motor fan housing. If the direction is opposite of the arrow, lock out the power and change two of the power leads into the motor. Check the direction once more to confirm that it is running in the proper direction.

6.2.4 During operation, ensure that the discharge pressure does not exceed the maximum continuous operating pressure as shown in Table 2-1. Adjust the pressure regulator to maintain the vacuum level desired by rotating the adjustment knob clockwise or counterclockwise, depending on adjustment desired.

6.3 The VCX and PCX generate a pulsation of plus or minus 0.4 Bar at 120 Hz frequency. This can cause resonance in downstream piping. If resonance occurs, noise will be much louder than predicted and downstream instrumentation and processes may not operate properly. Resonance can be eliminated by adding additional piping supports or by changing the downstream piping configuration. A

pulsation dampener can also reduce the amplitude of the pulsation to a point where it will not affect the piping or downstream processes. Contact your Airtech sales representative for assistance.

6.4 The VCX and PCX rotary claw machines have close internal clearances. To ensure proper operation, protect the pump from ingestion of liquids or solids by proper installation.

6.4.1 Install the inlet and discharge piping so that it slopes away from the pump.

6.4.2 If possible, install a knock-out pot in front of the VCX to avoid slugging the pump with water or other liquids from the process.

6.4.3 Protect the pump from solids ingestion by installing a properly sized filter at the suction of the VCX pump.

6.4.4 Always install a check valve on the inlet of a VCX pump operating on a vacuum application. Install a check valve on the inlet of the PCX valve or provide automated isolation from the pressure side of the system in PCX installation. Do not install a check valve in the discharge of a PCX system without first installing a pulsation dampener.

Caution: The VCX and PCX pumps must not be allowed to run backwards. The splash lubrication system is not designed for backward operation and this may result in premature failure of the rotary claw machine.

7.0 Routine Maintenance

7.1 Proper maintenance of the pump can extend its life by many years. Be sure to follow the recommended schedule of maintenance and use only genuine Airtech oil, grease and wearing parts to ensure proper fit and function of your pump.

Warning: Surfaces on the VCX and PCX machine can be very hot after operation. Allow the machine to cool to room temperature before attempting maintenance or repair of the unit.

Table 7-1 Recommended Maintenance Items

Item requiring Maintenance	Interval	What to check/do
Inlet filter	Monthly, more often if high particulates in inlet stream.	Check the inlet filter for contamination and clean or replace as necessary.
Gearbox oil	Check level monthly, change every 10,000 hours of operation.	Change when the oil becomes black or at 10,000 hours of operation. If oil level is reduced below the recommended level, check for leaks and repair. Add oil, but do not overfill.
Protective Mesh	Monthly	Check and clean as required. Use compressed air to clean it when necessary.
Fan and coupling	Semi-annually	Check for proper operation and replace when worn.
Bearings (VCX/PCX 500 only)	Annually, more frequently if ambient temperature exceeds 20 C on a consistent basis.	Regrease with Klueber Amblygon TA 15/2 or other equal grease. Do not over-grease; use a maximum of 30 grams of grease per bearing.

8.0 Troubleshooting Chart

Fault	Probable Cause	Remedy
Motor Starter Trips	Incorrect voltage lower than required.	Check voltage at the motor and correct any sources of voltage drop in the system. Check wiring to ensure it is properly sized according to National Electrical Code requirements.
	Incorrect wiring of the motor.	Ensure the motor is wired according to the instructions contained in the motor junction box. Correct placement of the bridges is necessary to configure your motor for the proper voltage.
	Motor starter is not set correctly or is too small for the application.	Check to ensure the motor starter is set for the full load amps at the operating voltage as indicated on the motor nameplate. Be sure to multiply the full load amperage by any service factor that appears on the motor. If the current required is outside the range of adjustability of the starter, replace the starter with a properly sized starter.
	Motor starter trips too fast.	A motor starter with a high current trip delay should be used to avoid nuisance trips on startup.
Insufficient Capacity	Blocked inlet mesh (VCX)	Check and clean mesh as necessary. Replace damaged mesh. Do not run the machine without the inlet mesh in place, as even small solids entering the pumping chamber can cause the unit to fail.

Insufficient Capacity (Cont'd)	Leaks in the vacuum piping (VCX)	Check process piping for leaks. To confirm the leaks are in the piping, run the pump isolated from the piping and confirm pump reaches ultimate vacuum per the data sheets. If the pump does meet the ultimate vacuum, then there is a problem in the piping that must be corrected. A rate of rise test can be run to determine the leakage rate. Leaks can be found by a soapy water test or smoke test on a vacuum system.
	Improperly operating relief valve (VCX)	Check the adjustment of the relief valve. Under normal conditions, the VCX should not have air flowing into the relief valve if operating in the standard range of pressures. If air is detected entering the relief valve (place a cardboard scrap near the suction of the relief valve and see if vacuum is detected – if the scrap is held to the relief valve by the vacuum, then the relief valve is active). If the relief valve is active, adjust it so that no flow is detected at the operating pressure, which must be in the range of operation shown on the data sheet.
	Obstruction in the inlet filter (PCX)	A blocked air inlet filter will throttle the air on the PCX low pressure compressor. Check the filter to ensure it is clean and replace if necessary.
	Leaks in the air piping (PCX)	Leaks downstream from the compressor will rob the process of capacity. Check for leaks using soapy water at all pipe joints. Only very large leaks are audible – a number of smaller leaks could result in underperformance and must be checked in a systematic manner.

Insufficient Capacity (Cont'd)	Improperly operating relief valve (PCX)	Check to see if air is coming out of the relief valve during normal operation in the allowed operating range. If the relief valve is passing air during normal operation, adjust it until it no longer passes air, making sure that the pressure does not exceed the rated pressure for the PCX/motor combination installed at your location.
Insufficient Pressure or Vacuum	Blocked inlet mesh	See blocked inlet mesh above.
	Improperly operating relief valve	See Improperly operating relief valve, above.
	Bad gauge	Replace the gauge with a good quality vacuum or pressure gauge.
	Leaks in the system piping.	See Leaks in the vacuum piping for VCX operation or leaks in the air piping for PCX operation above.
	Improperly sized piping.	Check the pressure at the pump and at the process with the same gauge. If the pressure drop exceeds the design value (rule of thumb is 10 percent of the operating pressure, maximum) then the piping is too small. Change the piping between the pump and the process to a larger size.
VCX does not achieve ultimate vacuum	Leak on the suction side	Check the piping for leaks as noted above.
	Relief valve set incorrectly.	Reset the relief valve as necessary.
	Bad gauge	Replace the gauge with a better quality vacuum gauge.
Operating Temperature too High	Ambient temperature too high	Operation of the VCX or PCX rotary claw machine requires cooling air to avoid overheating. Provide adequate ventilation for the installation area so that the ambient temperature never is above 104 F.

Operating Temperature too High (Cont'd)	Insufficient clearance around pump	If the clearance around the pump is too small, cooling air can not flow and the discharge temperature will increase. Allow at least six inches around all surfaces of the pump for cooling air flow and ensure the installation area is properly ventilated.
	Dirty or blocked mesh	Check the flow of the cooling air and clean the metal mesh of any debris blocking the air as necessary.
Piping melts on discharge	Improperly selected piping	PVC and CPVC piping should not be used on the discharge side of a claw pump without adequate cooling. Such piping melts at 120 to 140 F and the discharge of the pump may operate at up to 300 F, making use of such piping problematic. Use of a length of steel piping after the discharge may afford adequate cooling to allow use of downstream PVC piping. Do not use PVC piping on a pressure application.
Excessive or unusual noise	Contacting of the claws within the pump.	Unusual loud noise from the machine indicates a severe problem. Shut down the machine and contact your local Airtech service center for assistance.

9.0 Safety

- 9.1** Before repairs are attempted, be sure the power to the unit is off and locked out so accidental startup can not occur during repairs or troubleshooting.
- 9.2** When lifting the VCX or PCX pump, use proper and well maintained equipment to avoid injury.
- 9.3** Surfaces of the VCX and PCX pumps can be hot during normal operation. Do not attempt to work on the pump until it has cooled to room temperature.
- 9.4** Ensure the electrical installation is done by a qualified electrician in compliance with the National Electrical Code and all local laws and regulations. Failure to do so can cause extreme injury including death.

10.0 Storage

- 10.1** Store the unit in a clean dry place, using dessicant bags if humidity is expected to exceed 50% for long periods of time to avoid rusting of the internals of the machine. Rotation of the shaft by hand is recommended if storing for more than 6 months.

11.0 Disposal

- 11.1** Dispose of any waste oil in compliance with local codes and regulations.

VCX 100/250/300

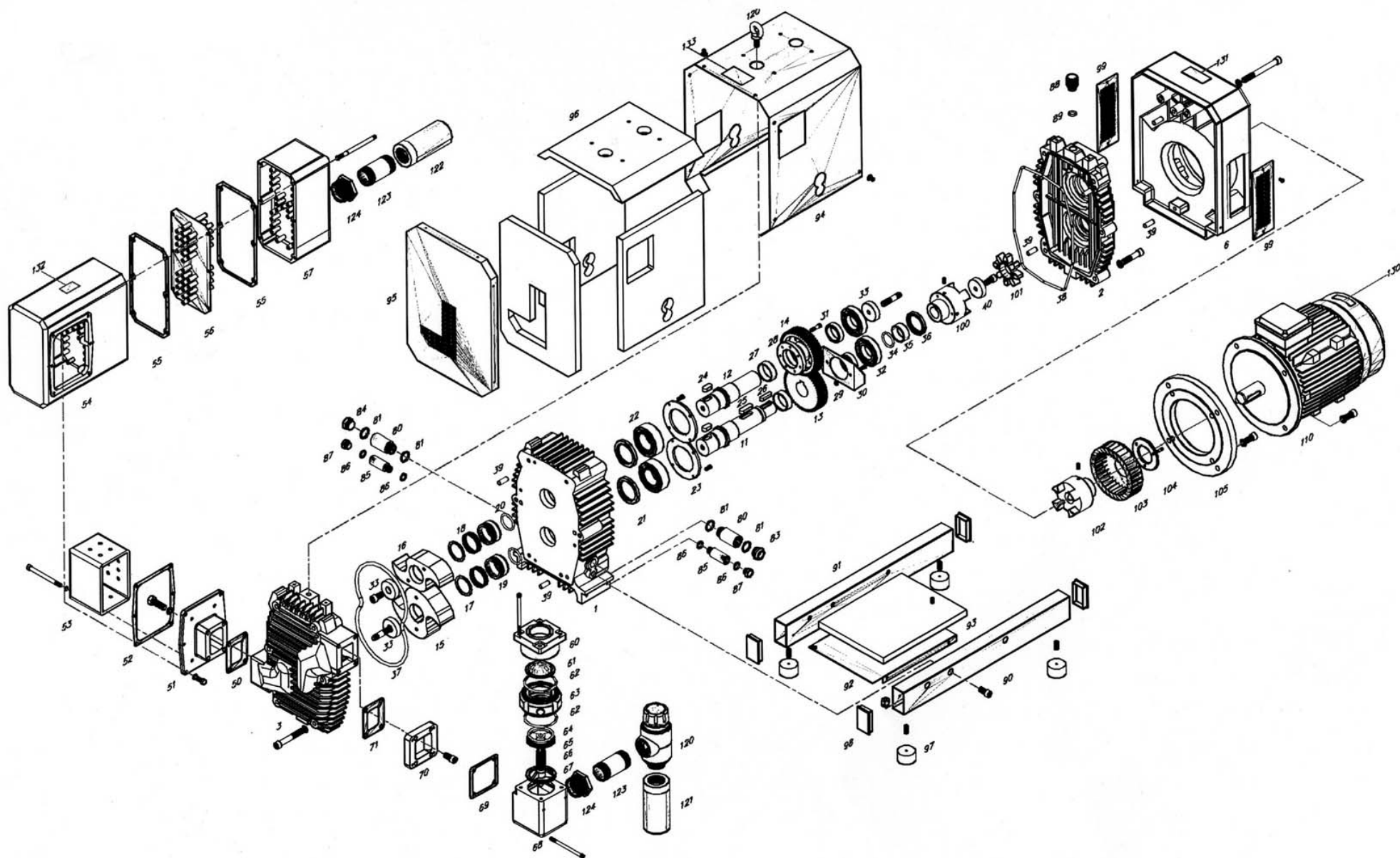

VCX 100/250/300 PARTS LIST

Pos. #	Description	Qty	Pos. #	Description	Qty	Pos. #	Description	Qty
1	Gear Box Housing	1	53	Inner Box of Exhaust Silencer	1	100	Coupling, Pump Side	1
2	Gear Box Cover	1	54	Exhaust Silencer, Front part	1	101	Insert, Coupling	1
3	Pump Housing	1	55	Gasket,	2	102	Coupling, Motor Side	1
6	Fan Housing	1	56	Plate, bulkhead	1	103	Fan	1
11	Shaft 1	1	57	Exhaust Silencer, Rear part	1	104	Cover Plate for fan	1
12	Shaft 2	1	59	Exhaust Silencer assembly	1	105	Flange Adapter for Motor	1
13	Gear 1	1	60	Inlet flange, Upper Housing	1	110	Motor	1
14	Gear 2	1	61	Inlet screen (Conical)	1	120	Vacuum Regulator	1
15	Rotor 1	1	62	O-Ring, Inlet Flange	2	121	Silencer, Inlet	1
16	Rotor 2	1	63	Inlet flange, Lower housing	1	122	Silencer, exhaust	1
17	Spacer	2	64	O-Ring, Check valve plate	1	123	Pipe, extension	2
18	Piston Ring	2	65	Check valve plate	1	124	Socket	2
19	Sleeve	2	66	Spring, Check valve	1	129	Eye Bolt	1
20	O-Ring	2	67	Check valve guide	1	130	Label, Direction Arrow	1
21	Shaft Seal	2	68	Inlet Connection Housing	1	131	Name Plate	1
22	Bearing	2	69	Gasket	1	132	Lable, Hot	1
23	Bearing cover	2	70	Flange Adapter, Inlet	1	133	Lable, read manul	1
24	Key, for Rotor	2	71	Gasket, Inlet	1			
25	Key, for Gear	1	80	Pipe, for Oil sight glass	2			
26	Key, for Coupling	1	81	Gasket, Oil Sight Glass	4			
27	Sleeve	2	83	Oil Sight Glass	1			
28	Power Lock	1	84	Plug for oil Sight Glass	1			
29	Wahser, Spring	2	85	Pipe, for Drain Pulg	2			
30	Flinger	1	86	Gasket, Drain Plug	4			
31	Sleeve	2	87	Drain Plug	2			
32	Bearing	2	88	Oil filler Breather	1			
33	Locking Disk	3	89	O-Ring for Oil filler	1			
34	O-Ring	1	90	Foot Mount, Right	1			
35	Sleeve	1	91	Foot Mount, Left	1			
36	Shaft Seal	1	92	Shield Cover, Bottom	1			
37	O-Ring, Compressor cover	1	93	Accoustic Mat for Shield Cover, Bottom	1			
38	O-Ring, Gear Box cover	1	94	Shield Cover, Side	1			
39	Dowel Pin	6	95	Shield Cover, Front	1			
40	Locking Disk	1	96	Accoustic Mat for Shield Cover	1			
50	Gasket, Exhaust Silencer	1	97	Foot, Rubber	4			
51	Inlet flange, Exhaust Silencer	1	98	Cover, Plastic Foot Mount	4			
52	Gasket	1	99	Grill for Fan	2			

VCX-500

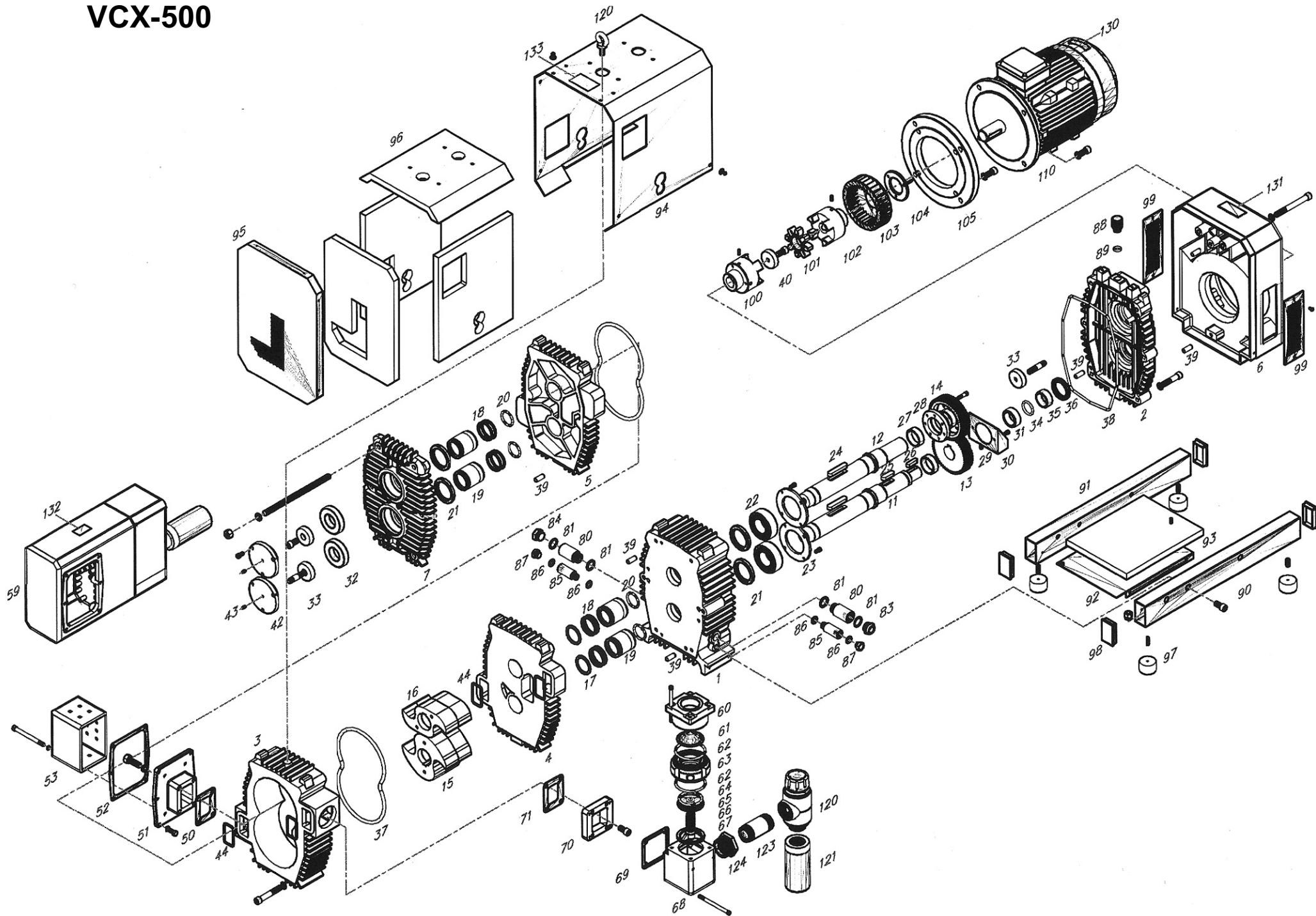

VCX - 500 PARTS LIST

Pos. #	Description	Qty	Pos. #	Description	Qty	Pos. #	Description	Qty
1	Gear Box Housing	1	50	Gasket, Exhaust Silencer	1	104	Cover Plate for fan	1
2	Gear Box Cover	1				105	Flange Adapter for Motor	1
3	Pump Housing	1				110	Motor	1
4	Housing Cover 1	1				120	Vacuum Regulator	1
5	Housing Cover 2	1	59	Exhaust Silencer Assembly	1	121	Silencer, Inlet	1
6	Fan Housing	1	60	Inlet flange, Upper Housing	1	122	Silencer, exhaust	1
7	Front Cover	1	61	Inlet screen (Conical)	1	123	Pipe, extension	2
11	Shaft 1	1	62	O-Ring, Inlet Flange	2	124	Socket	2
12	Shaft 2	1	63	Inlet flange, Lower housing	1	129	Eye Bolt	1
13	Gear 1	1	64	O-Ring, Check valve plate	1	130	Label, Direction Arrow	1
14	Gear 2	1	65	Check valve plate	1	131	Name Plate	1
15	Rotor 1	1	66	Spring, Check valve	1	132	Lable, Hot	1
16	Rotor 2	1	67	Check valve guide	1	133	Lable, read manul	1
17	Spacer	2	68	Inlet Connection Housing	1			
18	Piston Ring	4	69	Gasket	1			
19	Sleeve	4	70	Flange Adapter, Inlet	1			
20	O-Ring	4	71	Gasket, Inlet	1			
21	Shaft Seal	4	80	Pipe, for Oil sight glass	2			
22	Bearing, Angular Ball	2	81	Gasket, Oil Sight Glass	4			
23	Cover, Bearing	2	83	Oil Sight Glass	1			
24	Key, for Rotor	2	84	Plug for oil Sight Glass	1			
25	Key, for Gear	1	85	Pipe, for Drain Pulg	2			
26	Key, for Coupling	1	86	Gasket, Drain Plug	4			
27	Sleeve	2	87	Drain Plug	2			
28	Power Lock	1	88	Oil filler Breather	1			
29	Wahser, Spring	2	89	O-Ring for Oil filler	1			
30	Flinger, Oil	1	90	Foot Mount, Right	1			
31	Sleeve	1	91	Foot Mount, Left	1			
32	Bearing, Roller	2	92	Shield Cover, Bottom	1			
33	Locking Disk	3	93	Accoustic Mat for Shield Cover, Bottom	1			
34	O-Ring	1	94	Shield Cover, Side	1			
35	Sleeve	1	95	Shield Cover, Front	1			
36	Shaft Seal	1	96	Accoustic Mat for Shield Cover	1			
37	O-Ring, Compressor cover	2	97	Foot, Rubber	4			
38	O-Ring, Gear Box cover	1	98	Cover, Foot Mount	4			
39	Dowel Pin	6	99	Grill for Fan	2			
40	Locking Disk	1	100	Coupling, Pump Side	1			
42	Nipple, grease	2	101	Insert, Coupling	1			
43	Cover, Bearing	2	102	Coupling, Motor Side	1			
44	O-Ring	4	103	Fan	1			

AIRTECH[®]
VACUUM

150 South Van Brunt St.
Englewood, NJ 07631
Tel: 1-888-222-9940
Fax: 201-569-1696
airtech@airtechusa.com

AIRTECH[®] SOUTH
VACUUM

2211 Newmarket Parkway
Marietta, GA 30067
Tel: 770-690-0700
Fax: 770-690-0709
airtechsouth@airtechusa.com

AIRTECH[®] WEST
VACUUM

42 Digital Drive #9
Novato, CA 94949
Tel: 415-382-9000
Fax: 415-382-9700
airtechwest@airtechusa.com

AIRTECH[®]
CHINA

2nd Building,
Jiangbian Second Industrial Park
Songgang Town, Bao'an District
Shenzhen, China
Tel: +86-755-81730991(Ext.8018)
Fax: +86-755-81730986
www.airtechchina.com



Amsterdamstraße 16
D-97424 Schweinfurt, Germany
Tel: +49 (0)9721 94563-0
Fax: +49 (0)9721 94563-29
www.vacuvane.com



Hijo de J. Planas Escubós, S.L.
Av. de l'Aixernador, 35
08310 Argentona (Barcelona) - Spain
Tel: (+34) 93 797 17 66
Fax: (+34) 93 797 17 54
www.hpe-technology.com